

- NOTES:
1. ALL DIMENSIONS ARE IN METRES UNLESS OTHERWISE STATED.
  2. EARTHWORKS SIDE SLOPES ARE 1 IN 3 WHERE POSSIBLE. IN AREAS LIMITED BY LAND OR ENVIRONMENTAL RESTRICTIONS, STEEPER SLOPES HAVE BEEN GENERATED.

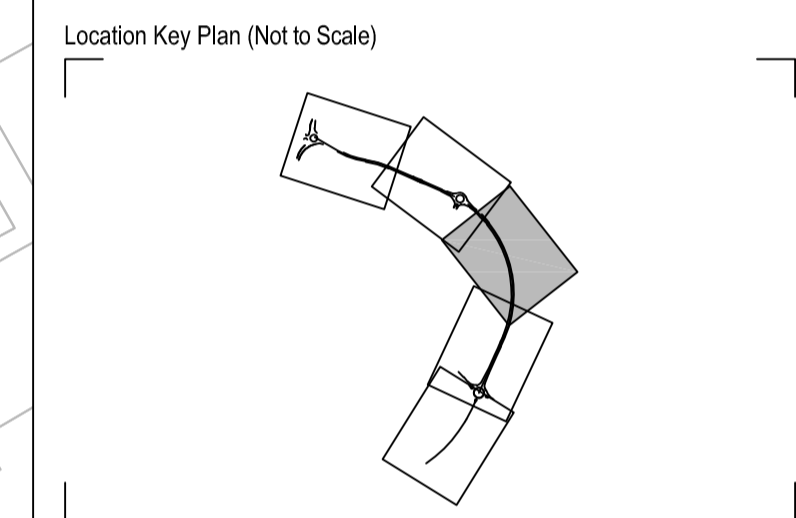

Rev	Drawn	Checked	App'd	Description	Date
P07	KS	KS	AB	KEY UPDATED AND LABELS ADDED	23.04.21
P06	JD	KS	AB	REDLINE BOUNDARY UPDATED, LANDSCAPE AND FENCING DETAILS ADDED	30.03.21
P05	LR	KS	AB	LABELS AMENDED	21.10.20
P04	LR	KS	AB	HIGHWAY LAYOUT AND REDLINE BOUNDARY UPDATED	16.10.20
P03	PD	KS	AB	KEY ADDED	03.09.20
P02	LR	KS	AB	LABELS ADDED / AMENDED	28.08.20
P01	PD	DAH	KS	FIRST ISSUE	12.08.20

Purpose of Issue  
**For Planning** **S0**

Classification  
**Public**



Project  
**A29 Realignment Scheme**

Drawing  
**Site Plan Sheet 3 of 5**

Scale @ A1	Drawn	Checked	Approved
1:500	PD	RP	KS

Project No. **CS099505** Date **12.06.20**

Drawing Identifier **A29-CAP-HPN-00-DR-C-0134** revision **P07**



Capita House, Wood Street, East Grinstead, RH19 1UU  
 01342 327161  
 www.capitaproperty.co.uk  
 Capita Property and Infrastructure Ltd.

**LANDSCAPING KEY:**

- REDLINE BOUNDARY
- EXISTING VEGETATION - TO BE RETAINED AS MUCH AS POSSIBLE. EXTENTS OF CLEARANCE IN THESE AREAS IS TO BE AGREED ON SITE WITH OVERSEEING ORGANISATION'S SITE SUPERVISOR
- TEMPORARY USE LAND, TO BE REINSTATED LAND BACK TO EXISTING
- TEMPORARY USE LAND, TO BE LEFT IN A TIDY STATE, NO NEED TO REINSTATE
- WOODLAND EDGE SW1 TOPSOIL 300MM - 450MM
- SCRUB SW2 TOPSOIL 300MM - 450MM
- SPECIMEN TREE SW3
- WILDFLOWER MEADOW GRASS MIX EM3 TOPSOIL 150MM
- WETLAND GRASS MIX EM8 TOPSOIL 150MM
- SUBMERGED AND FLOATING PLANTS FOR PONDS
- MARGINAL PLANTS FOR PONDS TOPSOIL 150MM
- PUBLIC RIGHT OF WAY SELF BINDING PATH GRAVEL
- WILDLIFE CROSSING
- INDICATIVE LIGHTING COLUMN WITH REFERENCE LETTER FOR THE LIGHTING UNIT TYPE (INCLUDING HEIGHT) AS SHOWN IN THE LIGHTING PLANS INCLUDED IN APPENDIX 10.2 OF THE REVISED ES

**FENCING KEY:**

- PROPOSED POST AND THREE RAIL MCHW H15 AND HEDGE.
- 3.0m ACOUSTIC FENCING REFER TO DRG A29-CAP-HPN-00-DR-C-0183 AND 0184 FOR DETAILS. CLIMBING PLANTS ON WEST SIDE.
- GATE REFER TO MCHW H17 GATE NO.1 WIDTH 4.5M, HEIGHT 1.175M GATE NO.2 WIDTH 4.5M, HEIGHT 1.175M GATE NO.3 WIDTH 4.5M, HEIGHT 1.175M
- FT 1 BADGER MESH FENCING, TO COMPLY TO MCHW H46 MESH TO BE BURIED 300MM DEEP AND RETURNED 300MM AND FIXED TO POST AND THREE RAIL FENCE. THE FENCING TO EXTEND AS SHOWN ON THE PLAN EITHER SIDE OF THE WILDLIFE CROSSING POINT
- PROPOSED POST AND THREE RAIL MCHW H15
- PROPOSED CLOSE BOARD FENCE PANELS TO MATCH EXISTING
- PROPOSED FENCING - HALO SITE CLOSE BOARD FENCE PANELS WITH GREEN MESH SECURITY FENCE TO MATCH EXISTING HALO FENCING.
- EXISTING FENCING - HALO SITE 1.8M CLOSE BOARD FENCE PANELS INC GRAVEL BOARD WITH 2.4M CENTRE OF CONCRETE POSTS 2.3M GREEN MESH SECURITY FENCE PANELS WITH 3.3M CENTRE OF GREEN METAL POST. SUPPLIER PROCTER - PRO-MESH PANEL FENCING SYSTEMS

**SWALE PLANTING PLAN**  
 10NO. SALIX ALBA VAR. VITELLINA 'BRITZENSIS'  
 25NO. FILIPENDULA ULMARIA (MEADOW SWEET) AND 25NO. PURPLE LOOSESTRIPE (LYTHRUM SALICARIA) EACH SIDE

**OTHER KEY:**

- TXX TREE PRESERVATION ORDER - INDICATIVE LOCATION ONLY
- ROOT PROTECTION AREA - INDICATIVE LOCATION ONLY
- SHARED USE FOOTWAY/CYCLEWAY BOUND SURFACE COURSE - ASPHALT CONCRETE
- FOOTWAY BOUND SURFACE COURSE - ASPHALT CONCRETE
- CARRIAGEWAY HRA SURFACE COURSE
- TRAFFIC ISLAND BOUND SURFACE COURSE - ASPHALT CONCRETE
- POND ACCESS TRACKS UNBOUND SUB BASE TYPE 1
- GRASSCRETE
- HEDGE
- CONSTRUCTION EXCLUSION ZONE - WHEREBY AVOID VEGETATION STRIP ALL TOGETHER AND CONSTRUCTION WORKS ACCESS IS EXCLUDED
- RESTRICTED WORKING ZONE - WHEREBY EXISTING VEGETATION IS ONLY STRIPPED WHERE ABSOLUTELY NECESSARY. WORKS WITHIN THESE AREAS TO BE SUBJECT TO TASK/ LOCATION SPECIFIC ARBORICULTURAL METHOD STATEMENT. THE AMS FOR EACH TO BE DEVELOPED DURING CONSTRUCTION PLANNING. THE WORK METHODOLOGY IS TO BE AGREED WITH THE ECOw/ ARBORICULTURIST. TREE PROTECTION FENCING REQUIREMENTS TO THESE AREAS TO BE AGREED WITH ARBORICULTURIST AND ECOw on site.
- ROOT BARRIER EACH SIDE OF FILTER DRAIN