

- NOTES:
1. ALL DIMENSIONS ARE IN METRES UNLESS OTHERWISE STATED.
 2. EARTHWORKS SIDE SLOPES ARE 1 IN 3 WHERE POSSIBLE. IN AREAS LIMITED BY LAND OR ENVIRONMENTAL RESTRICTIONS, STEEPER SLOPES HAVE BEEN GENERATED.

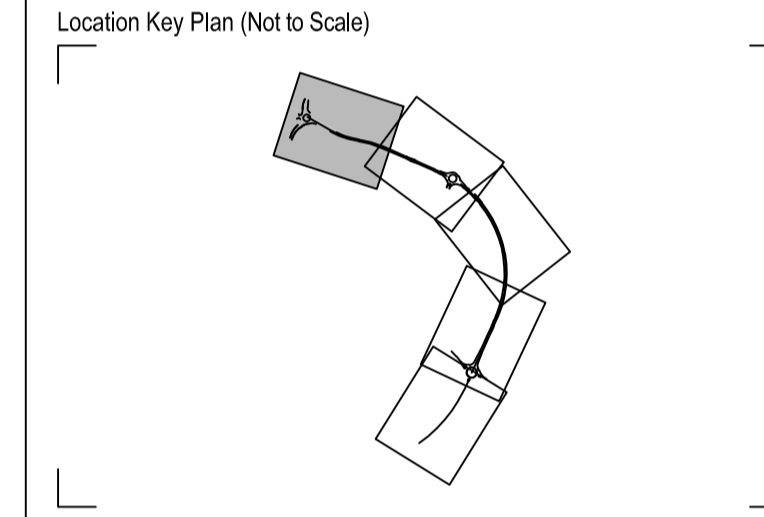

Rev	Drawn	Checked	App'd	Description	Date
P07	KS	KS	AB	KEY AMENDED AND LABELS ADDED	23.04.21
P06	JD	KS	AB	REDLINE BOUNDARY UPDATED, LANDSCAPING AND FENCING DETAILS ADDED	01.04.21
P05	LR	KS	AB	LABELS AMENDED	21.10.20
P04	LR	KS	AB	HIGHWAY LAYOUT AND REDLINE BOUNDARY UPDATED	16.10.20
P03	PD	KS	AB	KEY UPDATED	03.09.20
P02	LR	KS	AB	LABELS ADDED / AMENDED	28.08.20
P01	PD	DAH	KS	FIRST ISSUE	12.06.20

Purpose of Issue **SO**

For Planning **Public**



Project **A29 Realignment Scheme**

Drawing **Site Plan Sheet 1 of 5**

Scale @ A1	Drawn	Checked	Approved
1:500	PD	DAH	KS

Project No.	Date
CS099505	12.06.20

Drawing Identifier **A29-CAP-HPN-00-DR-C-0132** Revision **P07**



Capita House, Wood Street, East Grinstead, RH19 1UU
01342 327161
www.capitaproperty.co.uk
Capita Property and Infrastructure Ltd.