

This drawing is the copyright of Thrive Ltd ©. All rights reserved. Ordnance Survey Data © Crown Copyright. All rights reserved. Licence No. 100007359. DO NOT scale from this drawing. Contractors, Sub Contractors and Suppliers are to check all relevant dimensions and levels of the site and building before commencing any shop drawings or building work. Any discrepancies should be recorded to the Architect. Where applicable this drawing is to be read in conjunction with the Consultants' drawings.

REV	DESCRIPTION	DATE	AUTHOR	CHKD
A	Updated to planning status.	14.02.20	AJC	-
B	Amendments as per planning consultant comments.	17.02.20	AJC	-

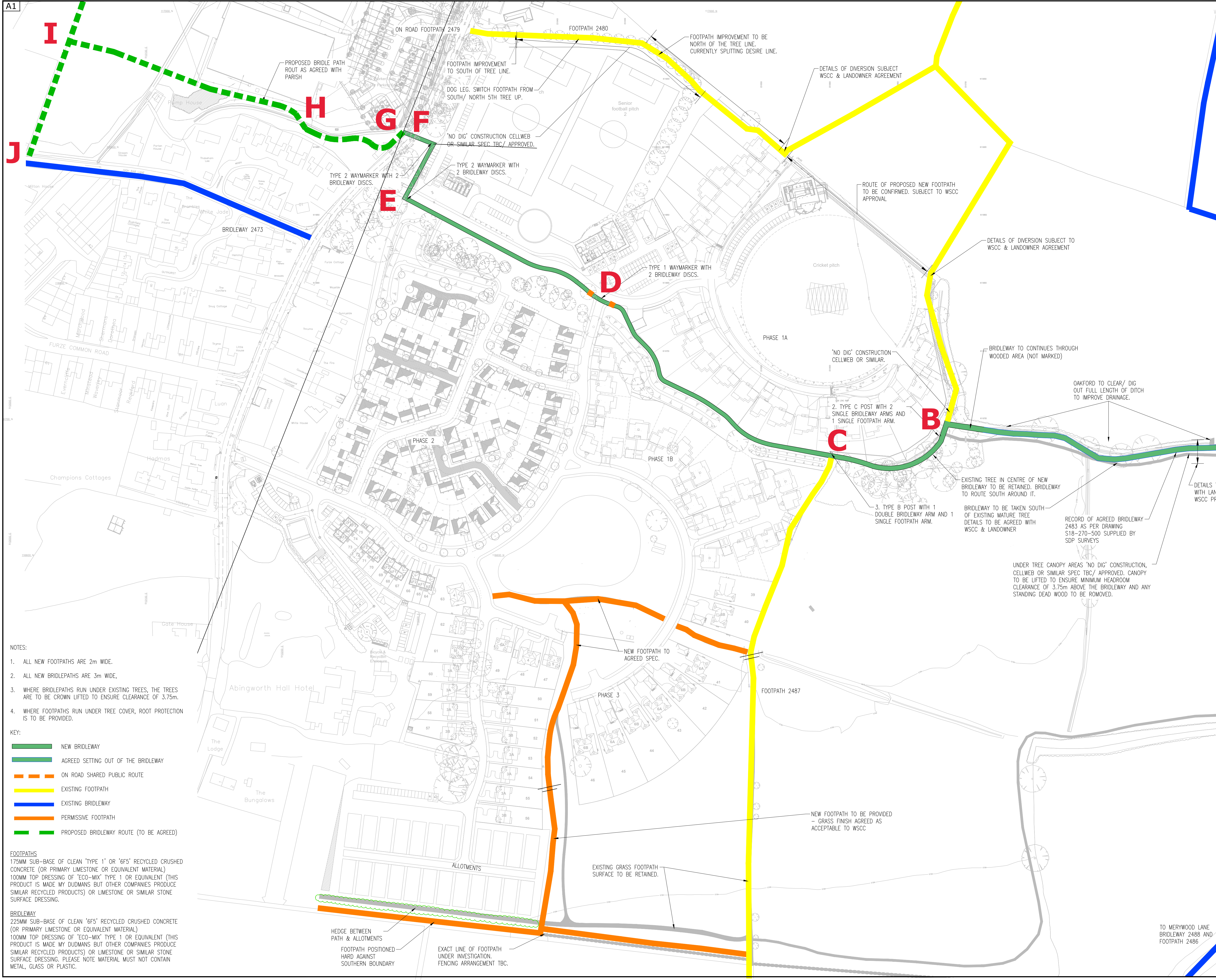

- NOTES:
- ALL NEW FOOTPATHS ARE 2m WIDE.
  - ALL NEW BRIDLEPATHS ARE 3m WIDE.
  - WHERE BRIDLEPATHS RUN UNDER EXISTING TREES, THE TREES ARE TO BE CROWN LIFTED TO ENSURE CLEARANCE OF 3.75m.
  - WHERE FOOTPATHS RUN UNDER TREE COVER, ROOT PROTECTION IS TO BE PROVIDED.

- KEY:
- NEW BRIDLEWAY
  - AGREED SETTING OUT OF THE BRIDLEWAY
  - ON ROAD SHARED PUBLIC ROUTE
  - EXISTING FOOTPATH
  - EXISTING BRIDLEWAY
  - PERMISSIVE FOOTPATH
  - PROPOSED BRIDLEWAY ROUTE (TO BE AGREED)

**FOOTPATHS**  
 175MM SUB-BASE OF CLEAN 'TYPE 1' OR '6F5' RECYCLED CRUSHED CONCRETE (OR PRIMARY LIMESTONE OR EQUIVALENT MATERIAL)  
 100MM TOP DRESSING OF 'ECO-MIX' TYPE 1 OR EQUIVALENT (THIS PRODUCT IS MADE BY DUDMANS BUT OTHER COMPANIES PRODUCE SIMILAR RECYCLED PRODUCTS) OR LIMESTONE OR SIMILAR STONE SURFACE DRESSING.

**BRIDLEWAY**  
 225MM SUB-BASE OF CLEAN '6F5' RECYCLED CRUSHED CONCRETE (OR PRIMARY LIMESTONE OR EQUIVALENT MATERIAL)  
 100MM TOP DRESSING OF 'ECO-MIX' TYPE 1 OR EQUIVALENT (THIS PRODUCT IS MADE BY DUDMANS BUT OTHER COMPANIES PRODUCE SIMILAR RECYCLED PRODUCTS) OR LIMESTONE OR SIMILAR STONE SURFACE DRESSING. PLEASE NOTE MATERIAL MUST NOT CONTAIN METAL, GLASS OR PLASTIC.

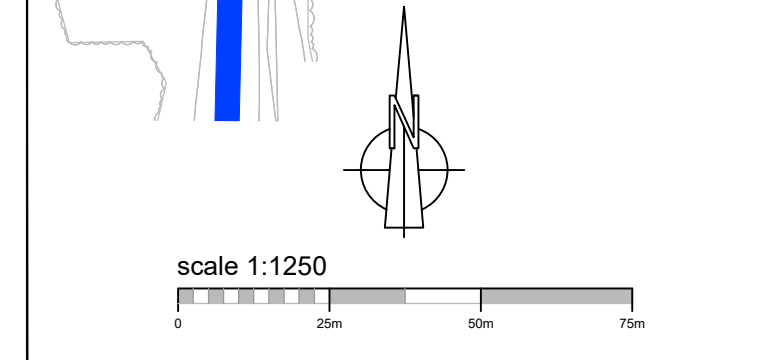

**thrive.**  
 architects  
 Portishead Office  
 Unit 5, Middle Bridge Business Park, Bristol Road, Portishead, BS20 6PN  
 t: 01275 407000 f: 01794 367276 www.thrivearchitects.co.uk

PROJECT  
**Abingworth Gardens - Phase 3**  
 Thakeham  
 For: Abingworth Farm Developments

DRAWING  
**Rights of Way Layout**

SCALE	DATE	AUTHOR	CHK'D
1:1250@ A1	Feb 2020	AJC	AJC
JOB NO.	DRAWING NO.	REV	
ABIN161107	ROW.01	B	
CLIENT REF.			

TO MERYWOOD LANE, BRIDLEWAY 2488 AND FOOTPATH 2486